

European Filter Solutions Ltd
Unit 3 Harworth Enterprise Park
Harworth, Doncaster. DN11 8SG

t. 01302 746545

f. 01302 595555

e. info@europeanfiltersolutions.com



European Filter Solutions Ltd

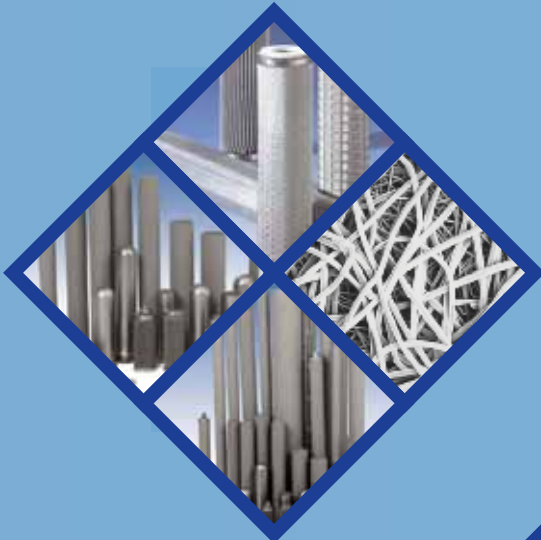

All Welded Stainless Steel Filters

AWSS All Welded Stainless Steel Filters

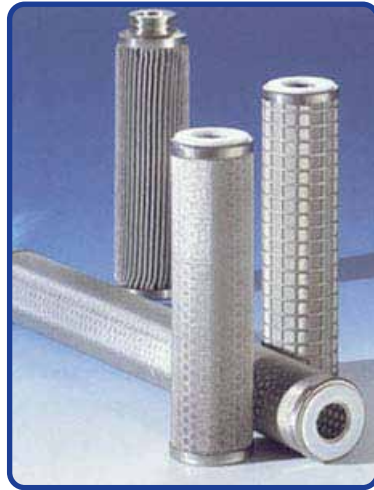

The AWSS filter cartridges are suitable for applications that require a robust filter cartridge resistant to aggressive chemicals.

AWSS filter cartridges are constructed from 316L grade stainless steel and assembled without the use of resins or adhesives. The filter media is TiG seam welded and the media, centre core and end fittings assembled using the same procedures.

AWSS cartridges have an operating range of -150°C to $+300^{\circ}\text{C}$ and up to 25 bar differential pressure.

Each AWSS filter cartridge is integrity tested prior to dispatch using a bubble point test in IPA.

Media options

SSM

Stainless steel mesh for filtration ratings 2 micron to 840 micron. These cartridges offer high permeability at low cost.

SSF

Stainless steel fibre for absolute filtration ratings of 3, 5, 10, 15, 20, 30, 40 and 60 microns. These cartridges offer high permeability, low differential pressure, high dirt capacity and a beta 5000 absolute rating.

SSP

Stainless steel powder for absolute filtration ratings of 15, 25, 40 and 60 microns. These cartridges are less permeable than the SSF product but are more robust, 100 bar differential pressure rating.

Cleaning

Reverse flow

Where most of the contamination is larger than the pore size of the filter media, reverse flowing the liquid or gas through the element will usually be adequate for cleaning. Typically, a flow of at least 2 times the forward flow provides good cleaning.

Ultrasonic cleaning

Again, surface contamination can be removed by ultrasonic cleaning in a bath containing detergent, deeply embedded particulate may not be removed.

Chemical cleaning

A variety of chemicals (solvents, acids, caustic etc) can be used to dissolve the contaminant or process fluid if it has hardened on contact with air.

High temperature burnout

Contact European Filter Solutions for detailed advice.

Code	Micron rating	Length	Grade	End cap 1	End cap 2	Gasket
AWSS	2 micron	5"	SSM	A = Open	A = Open	E = EPDM
	5 micron	10"	SSF	E=222	H = Spear	N = Nitrile
	10 micron	20"	SSP	F=226	G = Closed	S = Silicone
	15 micron	30"		T=Threaded		T = FEP
	20 micron	40"			V = Viton	
	40 micron					
	70 micron					
	100 micron					
	250 micron					
	450 micron					
840 micron						

AWSS Sintered Stainless Steel Fibre Filters

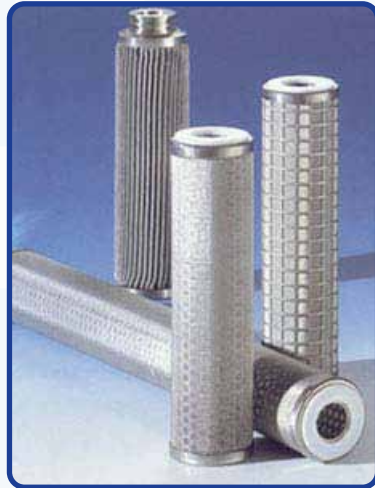

Sintered stainless steel fibre filter cartridges offer high permeability, high dirt holding capacity, and absolute micron ratings (beta 5000 99.98% efficient).

The sintered fibre filter cartridges are available in plain cylindrical form (0.05m² filtration area per 10" length) or pleated (0.135m² filtration area per 10" length). Both pleated and cylindrical cartridges are fully welded to ensure cartridge integrity and avoid by-pass. Pleated filters are available with a handling cage if required.

Cleaning

Reverse flow

Where most of the contamination is larger than the pore size of the filter media, reverse flowing the liquid or gas through the element will usually be adequate for cleaning. Typically, a flow of at least 2 times the forward flow provides good cleaning.

Ultrasonic cleaning

Again, surface contamination can be removed by ultrasonic cleaning in a bath containing detergent, deeply embedded particulate may not be removed.

Chemical cleaning

A variety of chemicals (solvents, acids, caustic etc) can be used to dissolve the contaminant or process fluid if it has hardened on contact with air.

High temperature burnout

In general, we do not recommend high temperature burn out for sintered fibre cartridges. Contact European Filter Solutions for detailed advice.

A full range of endcap styles are available, including 222, 226, DOE, fin, flanged and threaded options, all end caps are fully welded to the pleat pack.

Beta 5000 absolute micron ratings (liquid) of 3.0 to 60 are available as standard.

Maximum differential pressure in the normal flow direction should not exceed 25 bar, 3 bar in the reverse flow direction (with optional handling cage), and fibre filters are suitable for operating temperatures between -150°C and 300°C.



AWSS Sintered Powder Filter Cartridges



Sintered stainless steel powder is normally formed by compressing a controlled blend of metal particles into their "green" state and sintering them in a controlled atmosphere furnace into a rigid media. The resultant medium is typically between 2-3 mm thick, ungraded through its thickness and has a fairly tight pore size distribution. During the initial compression of the medium, the high pressures gives rise to a smooth surface finish and high density media with a maximum void volume of around 50%. This low voidage and high thickness leads to low permeability.

Sintered Powder Filter Cartridges

Sintered powder filter cartridges are suitable for applications with high temperature and high differential pressure requirements. Although they are typically less permeable than the equivalent fibre product they are extremely robust and suitable for use in the most demanding operating conditions.

The Sintered Powder filter cart wide range of materials, including stainless steel, titanium, nickel, bronze, Inconel, Monel and Hastelloy.

Available in diameters from 13.5 to 135mm, continuous lengths up to 1500mm, and with a full range of sinter bonded endcaps including 222, 226, flanged, threaded, closed and fin.

Cleaning

Reverse flow

Where most of the contamination is larger than the pore size of the filter media, reverse flowing the liquid or gas through the element will usually be adequate for cleaning. Typically, a flow of at least 2 times the forward flow provides good cleaning.

Ultrasonic cleaning

Again, surface contamination can be removed by ultrasonic cleaning in a bath containing detergent, deeply embedded particulate may not be removed.

Chemical cleaning

A variety of chemicals (solvents, acids, caustic etc) can be used to dissolve the contaminant or process fluid if it has hardened on contact with air.

High temperature burnout

Contact European Filter Solutions for detailed advice.

